

# COLMAR

**THINK RAILWAYS**



# COLMAR

Since 1963, the constant innovation, the performance based approach and the high safety standards, have taken COLMAR to a world leading position in the railway construction and maintenance sectors.

COLMAR operates with two manufacturing facilities in North Eastern Italy. Skilled and highly motivated employees manufacture all COLMAR design equipment, ensuring extraordinary quality and reliability over time.

With more than 4.000 machines successfully delivered worldwide, supported by a close and fast reacting sales and service network, including 3 owned companies in UK, USA and Russia, COLMAR assures its customers with the best solutions for railways construction and maintenance.

Finally, COLMAR's flexible Engineering staff can accommodate high degrees of product customization, thus meeting the most challenging market requests.



# MACHINES FOR THE CONSTRUCTION AND MAINTENANCE OF RAILWAYS

## INDEX

TAMPING MACHINE STAR TM04F LINE <b>STAR TM04 F</b>	4
TAMPING MACHINE STAR TM04M MULTIROLE <b>STAR TM04 M</b>	5
BALLAST REGULATOR <b>BPM220</b>	6
MACHINE TO REMOVE SLEEPERS <b>SR31</b>	7
RAIL CLAMP <b>RJ31</b>	8
SHUNTERS <b>SL LINE</b>	9
MOTOR TROLLEYS <b>MT</b>	10
INSPECTION CATENARY VEHICLE <b>TP85</b>	11
DIESEL LOCOMOTIVE <b>S500D</b>	12
AUTOMATIC CONVEYOR BELT FOR WAGONS LOADING <b>CB15</b>	13
BALLAST TRANSPORT SYSTEMS <b>MODULO 30</b> AND <b>MODULO 40</b>	14
BALLAST HANDLING SYSTEM <b>STI20</b>	16
PORTAL CRANE WITH ADJUSTABLE HEIGHT BRIDGE <b>QUBO TL</b>	18
HANDLING SYSTEM FOR TRACK SECTIONS <b>SP20</b>	19
RAIL TROLLEY <b>A25/A35</b>	20
PORTAL CRANE <b>T28/39T</b>	21
RAIL ROAD LOADERS <b>T7000FS T10000FS T10000HS T12000HS</b>	22
RAIL ROAD EXCAVATORS <b>T2400FSE T8000FSE</b>	23
RAIL ROAD TRACKED LOADER <b>T10000FSC</b>	24
RAIL ROAD TRACKED CRANE WITH REVERSE KNUCKLE TELESCOPIC BOOM <b>T10000FSCG</b>	25
AN ACCESSORY FOR EACH AND EVERY APPLICATION	26
RAIL SHEAR <b>RP2000</b>	27
SLEEPERS SPREADER BEAM <b>CBIPX</b>	27
TAMPING UNIT <b>TU03</b>	28
BALLAST BROOM <b>BB06</b>	29
WAGON FOR THE TRANSPORT OF RAIL ROAD LOADERS <b>WR02</b>	29

# STAR TM04 F

## TAMPING MACHINE STAR TM04F LINE

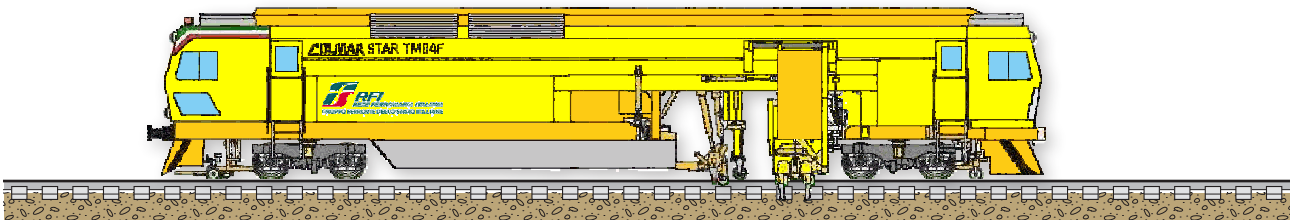

### COLMAR STAR TM04F LINE LEVELLING, LIFTING, LINING AND TAMPING MACHINE FOR PLAIN TRACK

#### TAMPING MACHINE STAR TM04F LINE

##### Structure

Frame made of sturdy electro-welded girders.  
Two bogies, two motorized axles  
Pneumatic brakes  
4 locking devices for the axle suspensions  
Continuous and automatic UIC brake  
Two emergency braking valves  
Direct brake.  
Parking brake.

##### Checking, Measuring, Recording

The tamping machine is equipped with a computerized system for data processing and job planning. The measuring system allows the recording of the following parameters:

- Gauge,
- Transversal level,
- Alignment to the rail,
- Longitudinal level.

##### Technical characteristics:

Weight .....	75 t
Length .....	27.000 mm
Max width .....	2.500 mm
Wheel base, inter axis pivot bogies .....	14.000 mm
Wheel Diameter .....	920 mm
Minimum radius in self propelled mode .....	90 m
Minimum radius in working mode .....	150 m
Minimum radius in convoy mode .....	150 m
Max speed in self propelled mode (straight and level rail) .....	100 km/h
Max speed in convoy mode .....	100 km/h
Engine .....	Diesel
Power .....	520 kW
N° 2 independents Tamping units with 16 tines	
Centralized lubrication of the tamping units	
Lifting/aligning system .....	3 rail rows
Shift of lifting system of 3.000mm from track longitudinal axis	
Nebulisation system for dust suppression.	
Soundproof front cabin.	
Soundproof rear cabin.	
Working cabin.	

##### Optional:

Regulating unit.  
Rotating brush.

## TAMPING MACHINE STAR TM04M MULTIROLE

# STAR TM04 M

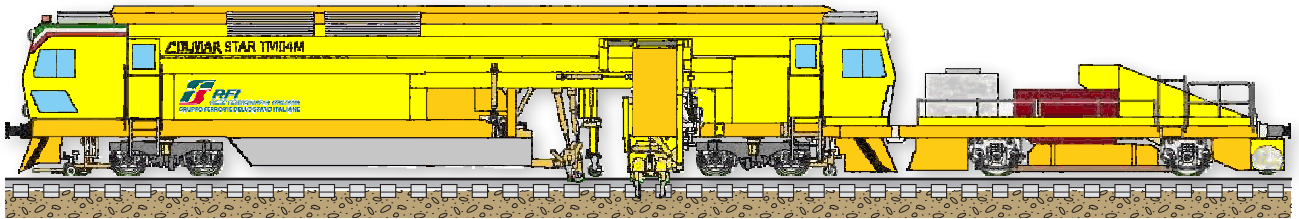

**COLMAR STAR TM04M MULTIROLE**  
**LEVELLING, LIFTING, LINING AND TAMPING MACHINE FOR PLAIN TRACK AND TURNOUTS**

### TAMPING MACHINE STAR TM04M MULTIROLE

#### Structure

Frame made of sturdy electro-welded girders.  
Two bogies, two motorized axles  
Pneumatic brakes  
4 locking devices for the axle suspensions  
Continuous and automatic UIC brake  
Two emergency braking valves  
Direct brake.  
Parking brake.

#### Checking, Measuring, Recording

The tamping machine is equipped with rope/sag system to measure track geometric parameters, computerized system for data processing and job planning. The measuring system allow the recording of the following parameters.:

- Gauge,
- Transversal level,
- Alignment to the rail,
- Longitudinal level,
- Skew,
- Sensor to measuring the geometry of the track when loaded.

#### Technical characteristics:

Weight .....	75 t
Length .....	27.000 mm
Max width .....	2.500 mm
Wheel base, inter axis pivot bogies .....	14.000 mm
Wheel Diameter .....	920 mm
Minimum radius in self propelled mode .....	90 m
Minimum radius in working mode .....	150 m
Minimum radius in convoy mode .....	150 m
Max speed in self propelled mode (straight and level rail) .....	100 km/h
Max speed in convoy mode .....	100 km/h
Engine .....	Diesel
Power .....	520 kW
N° 4 independent Tamping units with 16 tines / longitudinal advancement 500 mm / sidewise movement 2.500mm from track longitudinal axis	
Centralized lubrication of the tamping units	
Lifting/aligning system .....	3 rail rows
Shift of lifting system of 3.000mm from track longitudinal axis	
Longitudinal advancement	
Nebulisation system for dust suppression.	
Soundproof front cabin.	
Soundproof rear cabin.	
Working cabin.	
Rotating brush.	
Hopper for ballast/ conveyor belt from revolving brush.	

#### Optional:

Regulating unit.  
Compacting units.

# BPM220

## BALLAST REGULATOR

Feed direction

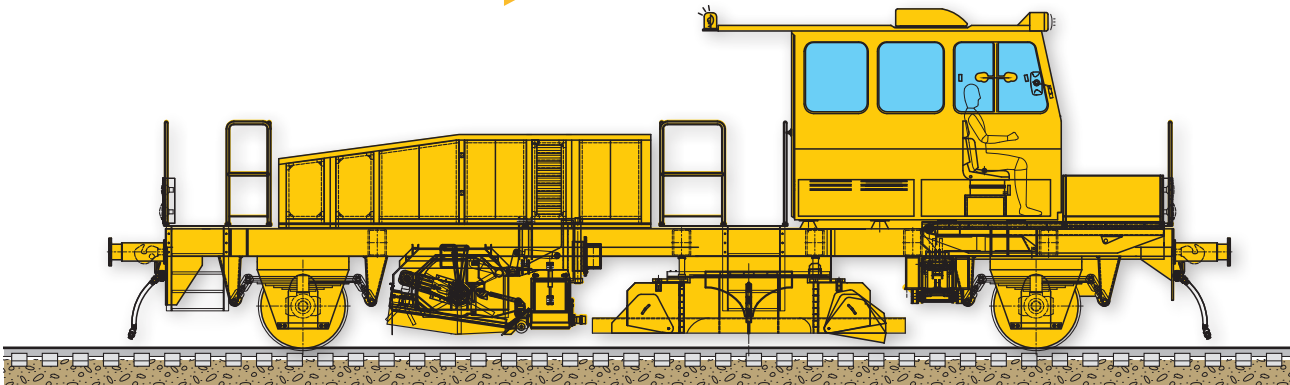

### THE MACHINE CAN BE MADE AVAILABLE FOR ALL RAIL GAUGES.

The BALLAST REGULATOR BPM220 consists of  
 Electro-welded steel structure frame.  
 N.2 drive axles.  
 Chevron-type suspension or laminated suspension spring.  
 Hydrostatic drive with closed circuit.  
 No.2 bi-directional central ploughs  
 No.2 side ploughs for track bench profiling  
 No.1 brush for excess ballast removal  
 Direct and indirect braking system.  
 Parking brake, Tristop negative.  
 Control and drive electric system.  
 Lighting system for night work.  
 Acoustic signaling.  
 Soundproof, air conditioned and pressurized cabin.

### Technical characteristics:

Diesel engine .....	220 kW
Max length .....	12.000 mm
Max width .....	3.100 mm
Max height .....	3.800 mm
Bogie pitch .....	5.500 mm
Track gauge .....	All
Wheel diameter .....	850 mm
Weight .....	30 t
Max speed .....	80 km/h
Working speed .....	0-30 km/h

### Optional:

Water sprinklers for Dust Suppression.  
 Cleaning Brushes for Couplers.

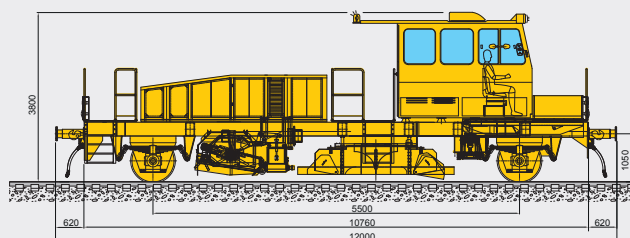

## MACHINE TO REMOVE SLEEPERS

# SR31

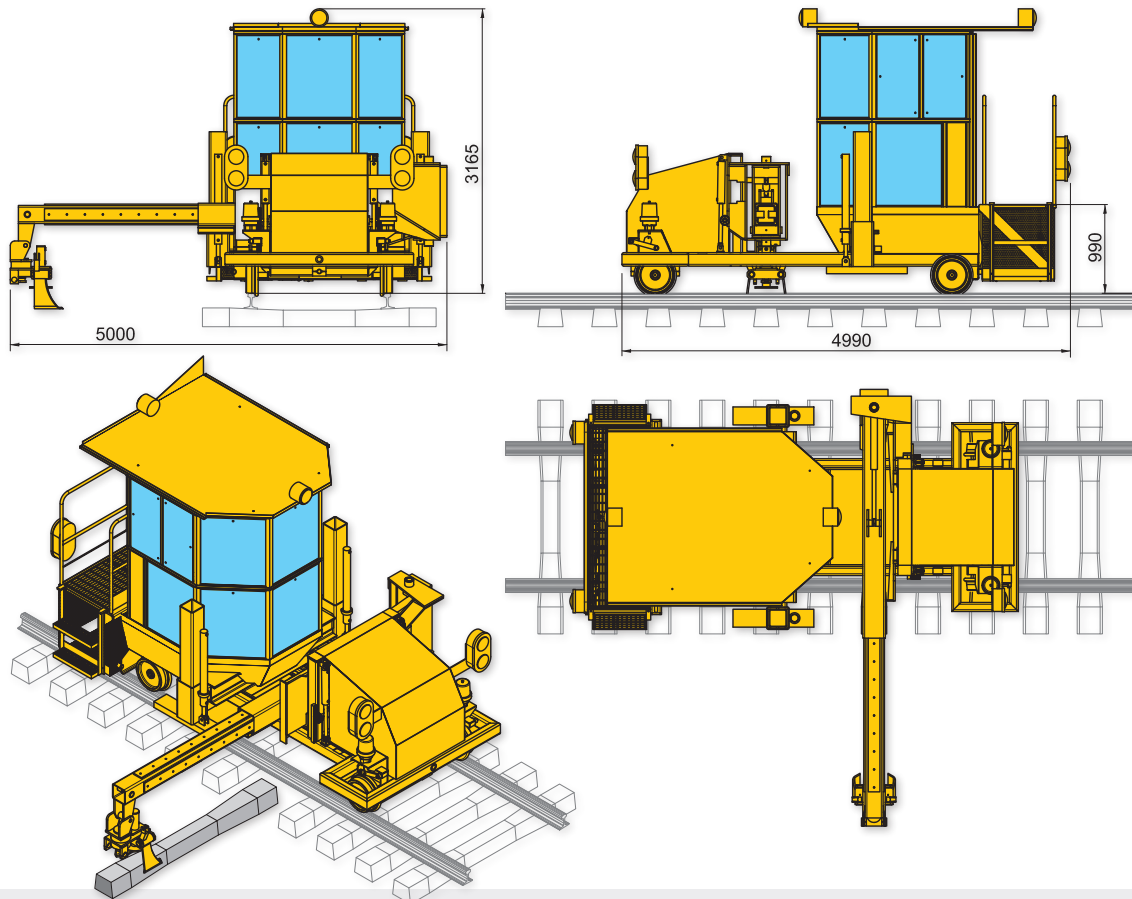

### Structure:

Made of electro-welded metallic beams.  
Front and rear tow bars.

### Diesel engine:

Fixed to the frame, by means of adequate rubber buffers.

### Transmission:

Hydrostatic transmission.

### Controls for operating the device:

From the operator seat or by radio control.

### Pincer for removal / replacement of sleepers:

The pincer travel is longer than 2.000 mm; removal of the old sleeper, and insertion of a new sleeper, in just one operating cycle. Suitable to turnouts.

Pincer rotation  $\pm 90^\circ$ , vertical inclination  $\pm 16^\circ$ .

### Production Capacity:

Time spent for either the removal or the insertion of a sleeper made in either cement or wood, is 60 seconds at normal working conditions or on elevated tracks.

### Predisposition for accessories:

The machine is complete with a derailment and translation system, as well as a rotating equipment to reverse the travelling direction.

### THE MACHINE CAN BE MADE AVAILABLE FOR ALL RAIL GAUGES.

### Facilities for flexibility

To increase the versatility of this equipment, the sleeper removal can be substituted with the tamping unit.

### Technical characteristics:

Axles .....	n° 2
Weight .....	8.0 t
Length .....	4.990 mm
Width .....	2.500 mm
Height .....	3.165 mm
Wheel base .....	2.000 mm
Diameter of the wheels .....	400 mm
Diesel engine .....	45 kW
Braking (shoe brakes) .....	direct
Parking brake .....	automatic
Electric installation .....	24 V
Max sped in plane .....	30 km/h
Gradient .....	36 ‰
Fuel tank capacity .....	100 l
Hydraulic oil tank capacity .....	200 l

# RJ31

## RAIL CLAMP

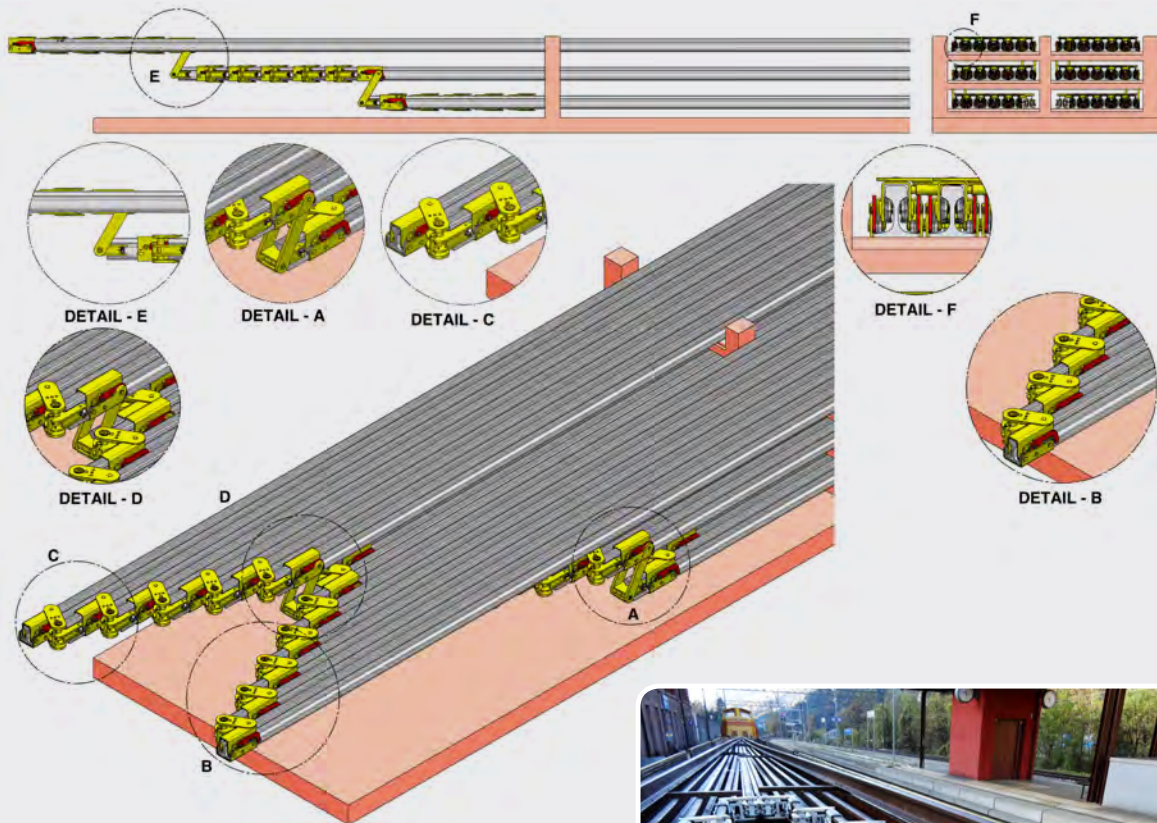
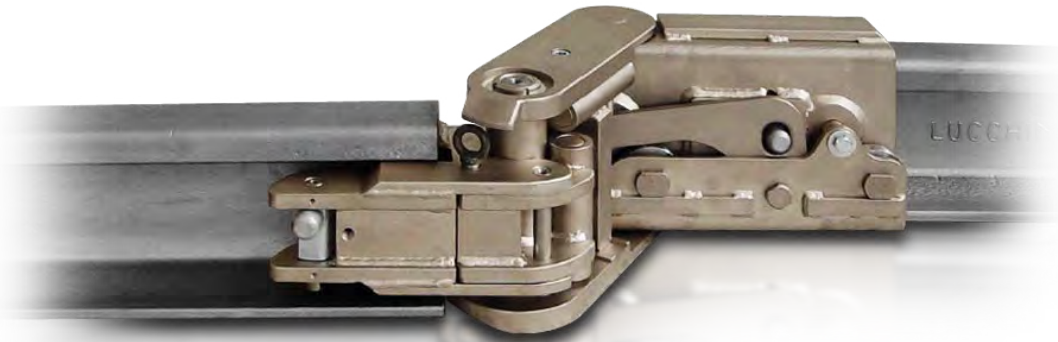

In order to prevent several accidents at work during the unloading of the rails, we have designed new solutions to increase safety and, at the same time, to reduce rail unloading time.

With our new system the clamps are being positioned directly on the rails before the train leaves the manufacturing plant. In this way, the train doesn't need to stop during unloading operations, and the rails are discharged without interruptions.





# MT

## MOTOR TROLLEYS

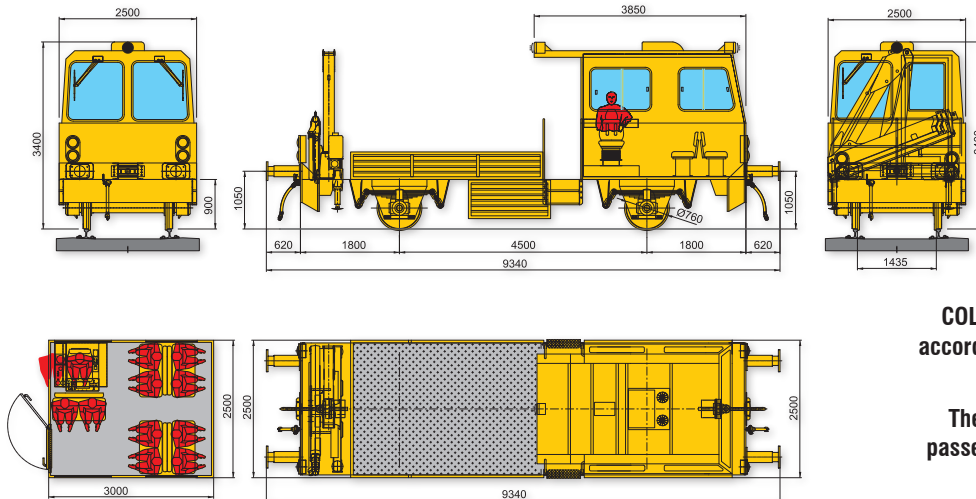

COLMAR motor trolleys can be made according to customer's specifications, and for all rail gauges.

They can be equipped with cabin for passenger transport, loading platform, material lifting crane, and other specific accessories on demand.

**Cabin:** Made of electro-welded steel structure, complete with thermo and acoustic isolation, attached to the frame with "silent blocks" to reduce vibrations to the minimum. Wide security glasses, on the front and side with sun visors and electric screen wipers. The floor is made of marine plywood totally covered by a black fireproof bubble plastic carpet. The cab is equipped with A/C, pressurization system with dust and pollen filters. It also contains an ergonomic adjustable driver seat and seats for crew. Control Panels. Inside seats for the crew. Cabin access via side swinging door. Security key locks

**Chassis:** Strong chassis structure made of electro welded steel girders. Two robust heads, on which towing and shocking hooks are bolted, are fixed to the two ends through electro-welding.

**Wheel arrangement:** The wheel arrangement is made of forged axles. Wheel bearings are driven onto hubs, whose surface is ground. The bushes are with roller bearings. Wheels are one piece steel type. Axles are fastened to the chassis by means of a system of steel leaf springs. Furthermore, axles lay directly on the bushing unit with centering pivot and are equipped with fixing brackets and four shock absorbers.

**Engine:** Diesel Engine. Stiffly anchored to the chassis by rubber buffers, silencer with ant particulate filter.

**Transmission:** Hydrostatic with closed circuit, or hydrodynamic with power shift, or mechanic.

**Braking system:** Direct pneumatic, parking brake negative Tristop

MODELL		MT75	MT85C	MT116C	MT188C
Wheel base	mm	3.800	3.600	4.800	4.500
Weight	t	9	12	13,5	15,5
Length	mm	6.860	7.870	7.900	8.200
Widht	mm	2.560	2.800	2.700	2.700
Height	mm	3.600	4.040	3.700	3.600
Gauge		U.I.C.	U.I.C.	U.I.C.	U.I.C.
Driver + Crew	n°	1 + 8	1 + 7	1 + 10	1 + 16
Platform - Carrying capacity	t	N.P. *	4	5	6,5
Crane - Lifting capacity	t x m	N.P. *	10,5	13	10,5
Diesel engine	kW	75	85	116	188
Gear speeds		6+6 Power shift Hydrodinamics	Hydrostatic	6+6 Power shift Hydrodinamics	Hydrostatic
Brakes		Pneumatic	Pneumatic	Pneumatic	Pneumatic
Parking brake		Negative Tristop	Negative Tristop	Negative Tristop	Negative Tristop
Max speed	km/h	80	60	80	80
Tank capacity	l	200	200	1000	500

(\*) N.P. = Not foreseen

Mechanical, Hydrodynamic, and Hydrostatic Drives

## INSPECTION CATENARY VEHICLE

# TP85

Lateral access, from both sides, to the terrace, to the control cabin or to the working platform.

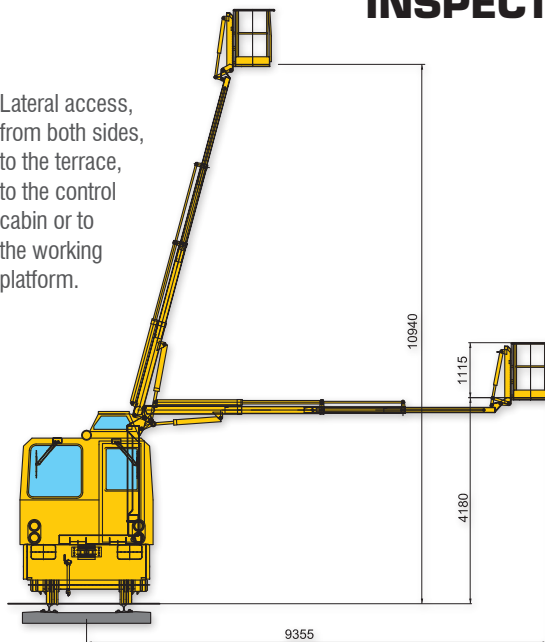

COLMAR Telescopic Rolling Platforms can be custom made to fit customer specifications, as well as for all rail gauges.

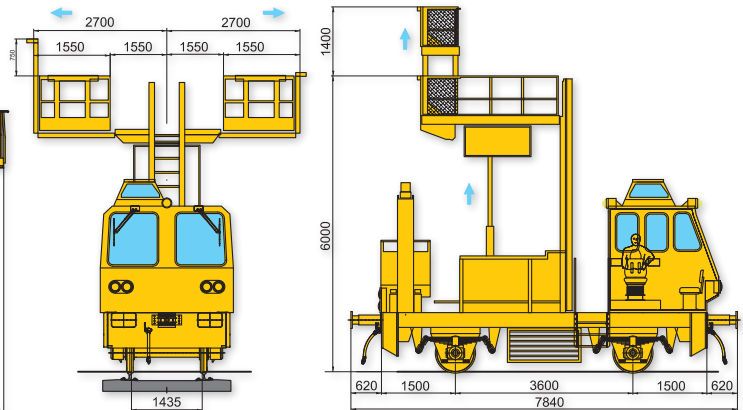

**Cabin:** Made of a electro-welded steel structure, with acoustic and thermo isolation; fixed to the frame on “ silent blocks “ to reduce vibrations tot he minimum. Wide Front & Side security glasses. Front glasses with sun visors and electric screen wipers.

The floor is made of marine plywood totally covered by a black fireproof bubble plastic carpet. The cab is equipped with A/C, pressurization system with dust and pollen filters.

The cab is equipped with

- Ergonomic driver seat
- Crew Seats
- Panoramic turret and rotating seat

**Chassis:** The main structure of the vehicle is a strong chassis made of electro-welded steel girders. The two robust heads, of suitable thickness, on which towing and shocking hooks are bolted, are fixed to the two ends by means of electro welding.

**Wheel arrangement:** The wheel arrangement is made of forged axles in accordance to the current regulations. Wheel bearings are driven onto hubs whose surface is ground. The bushes are with roller bearings. Wheels are one-piece steel.

Axles are fastened to the chassis through a system of steel leaf springs, axles lay directly on the bushing unit with centering pivot and are equipped with fixing brackets and four shock absorbers.

**Engine:** Diesel Engine in accordance to the local regulations. Fixed to the frame by rubber tampons, exhaust system with particulate filter.

**Transmission:** Hydrostatic with closed circuit. Front traction.

**Braking system:** Direct pneumatic, Tristop negative parking brake.

**Working platforms:** Elevation by means of hydraulic cylinder, Max Height: 4.800 mm from the rail plane, security valve block. Translation capacity on the horizontal plane of 1.500 mm, to both sides.

The working platform has a fixed second platform that can rise vertically of further 1.400 mm, with a security locking valve. Security lock controls the movement of the platforms. The main platform contains two telescopic supports with air line cables of 800 mm elevation, independent control one from the other, and locking vales.

**Crane:** Outreach, in respect to the rail, of 9.000 mm on the right side and of 7.700 mm on the left side and Maximum elevation of 11.000 mm.

### Technical characteristics

Length (with buffers) .....	7.900 mm
Max Width .....	2.800 mm
Max Height .....	4.050 mm
Wheel base .....	3.600 mm
Weight (empty) .....	16 t
Wheel diameter .....	760 mm

### Brake system

Direct brake (during working) .....	Automatic brake KE
Parking brake .....	Tristop
Brake cylinders.....	n° 4

### Speed

Max speed .....	80 km/h
Working Max Speed .....	0 - 4 km/h
Min. radius on curve .....	80 m

### Filling quantity

Gas oil tank .....	120 l
Hydraulic oil tank .....	200 l
Air compressor .....	150 cc
Air brake tank .....	80 l
Air services tank .....	100 l

### Diesel Engine

Power .....	85 kW
-------------	-------

# S500D

## DIESEL LOCOMOTIVE

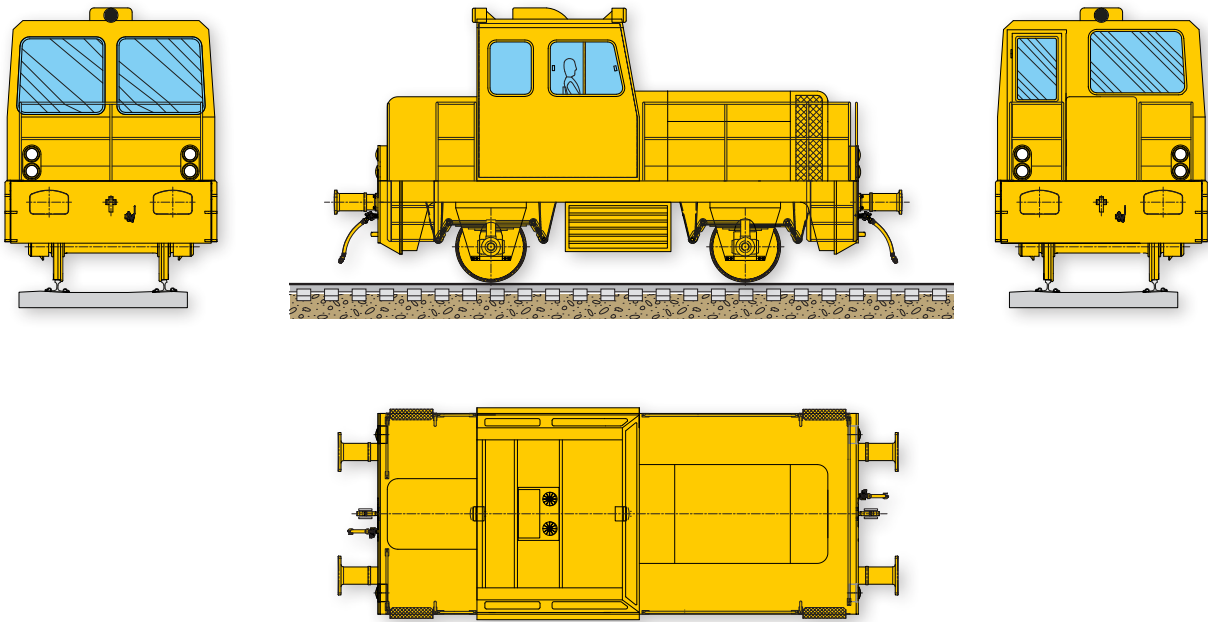

### OUR DIESEL LOCOMOTIVES CAN BE MADE AVAILABLE FOR ALL RAIL GAUGES

#### Cabin:

Made of a electro – welded steel structure, with thermo and acoustic isolation, attached to the frame with “silent blocks “ to reduce vibrations to the minimum. Wide security glasses, on the front and side with sun visors and electric screen wipers. The cab has excellent visibility to all around 360°. The cab is equipped with A/C pressurization system with dust and pollen filters. It also contains an ergonomic adjustable driver seat and one additional seat for the crew. Control panels. Cabin access via side swinging door. Security key locks.

#### Chassis:

Structure strong Chassis made on electro welded steel girders.  
 N. 4 Buffers - UIC 526 -1  
 N. 2 Coupler – UIC 825 and UIC 826

#### Wheel arrangement:

The wheel arrangement is made of forged axles. Wheel bearings are driven onto hubs, whose surface is ground. The bushes are with roller bearing. Wheels are one piece steel type. Axle are fastened to the chassis by means of a system of steel leaf springs. Furthermore axles lay directly on the bushing unit with centering pivot and are equipped with fixing brackets and four shock absorbers

**Engine:** Diesel Engine. Stiffly anchored to the chassis by rubber buffers, silencer with particulate filter.

**Transmission:** Hydrostatic with closed circuit.

**Braking system:** Direct pneumatic, parking brake negative tristop. Screw air compressor – 1500 l/min. – for wagons braking.

#### Technical characteristics:

Wheel base .....	3.600 t
Weight .....	40 t
Length .....	8.000 mm
Width .....	3.000 mm
Height .....	3.850 mm
Diesel Engine .....	418 Kw
Gear speeds .....	Hydrostatic
Brakes .....	Pneumatic
Parking brake .....	Negative Tristop
Max speed .....	60 Km/h
Drawbar pull .....	110 kN
Max pulling speed .....	40 Km/h
Min. towing capacity, slope 6% .....	>300t
Min. towing capacity, slope 0% .....	> 600t

## AUTOMATIC CONVEYOR BELT FOR WAGONS LOADING

# CB15



The Automatic Conveyor Belt for Loading Wagons has been designed and made for loading wagons that transport and unload ballast.

It can be accommodated to customer specifications.

The CB15 belt can be placed on the rail wagon and can be easily transported by standard road trailer. The system is composed of a rubber belt having roller supports and driven by a Diesel engine.

The ballast moves from the ballast-cleaning machine at the head of the train. During this ballast transfer, the operator can decide from which wagon he will start the load (generally from the last unit).

The machine can be operated automatically through radio control. The deflector of the trolley descends on the rubber belt, forcing the ballast to fall inside the wagon below (plough effect). With double-powered sensor system, the PLC drives independently the load of the wagon until the procedure is completed. Once the loading process is completed, the PLC installed on every single belt activates the automatic cycle of the preceding belt until the loading of all wagons is completed. After the loading operation, the belt places the trolley at the point of rest and stops. It is possible to keep the engine on if necessary while working during the night. Thanks to this automatic system, one operator is able to manage the load of more than one wagon, following the working operations on the monitor installed on each belt, thus avoiding dangerous maneuvers of climb and descent from the wagons.

An electric board operates the whole system with PLC pushbutton to control 10 belts simultaneously or independently.

### SAFETY

#### Stop devices:

- Bonnet (rear area);
- 1 button for engine stop.

#### Main radio control:

- 1 emergency stop button - for all the belts;
- 1 emergency stop button selected engine.

### Technical characteristics:

#### Technical data WORK MODE (UNFOLDED)

Length Max .....	15.500 mm
Width Max .....	2.740 mm
Height Max .....	2.200 mm
Material flow Max of belt .....	900 m <sup>3</sup> /h

#### Technical data TRANSFER MODE (FOLDED)

Length .....	13.500 mm
Width .....	2.460 mm
Height .....	2.000 mm
Tare .....	6.000 kg

#### Diesel Engine

Number of cylinders .....	4 in line
Power .....	25 kW

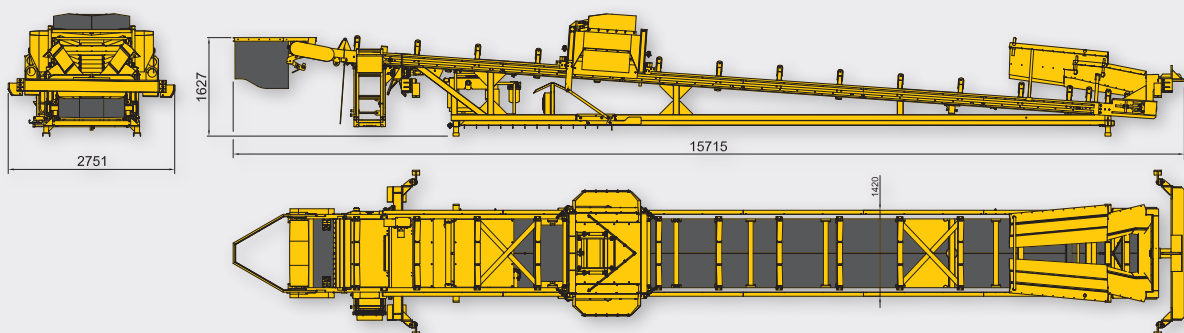

# MODULO 30

# MODULO 40

## BALLAST TRANSPORT SYSTEMS

### Preparation, filling and emptying:

The conveying and silos units for waste material of "Modulo" type, are designed and manufactured as standard containers to be arranged on standard flat wagons.

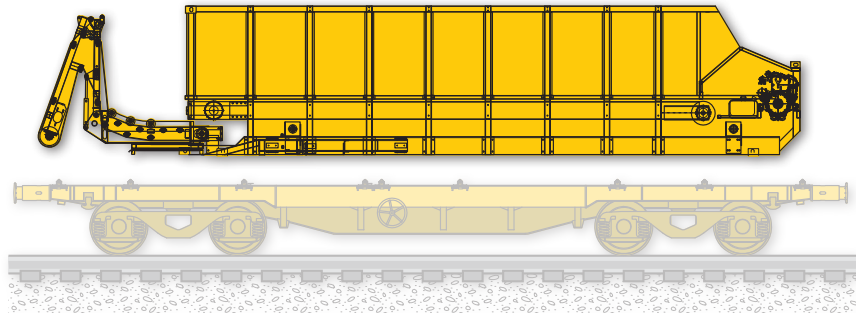

Big quantities of waste material that must be correctly disposed result from the renewal of ballast and different tracks. In the past, such waste material was usually deposited along the track; nowadays, stricter rules require transporting it to a suitable place for discharging and disposal. In particular cases, such as stations, tunnels or trenches, the only possible solution is to load the waste material on wagons.

A rapid and flexible way to transport new ballast is a task that requires a feasible and convenient solution.

**MODULO** meets following requirements:

- Full automation of loading, conveying, accumulation and discharging operations;
- Adaptation to the site conditions or to the specific task, without any problems;
- Optimization of the Ballast Cleaning Machine performances;
- Reduction of labour costs;
- Each "Modulo" has its individual power supply.



### Load and transport of the waste material from the Ballast Cleaning Machine:

The conveyor belt on the front side of "Modulo" is designed in such a way that it can slew on the 3 axes (x, y and z). The conveyor belt transports the waste material to the next "Modulo" during loading operations. By rotating the conveyor belt it is also possible to discharge the waste material or ballast on the side of the track, both to the left and to the right, or on other wagons and road vehicles. A certain number of "Modulo" units, positioned on railway wagons, can be used to transport any kind of material and travel in train compositions of the required length.

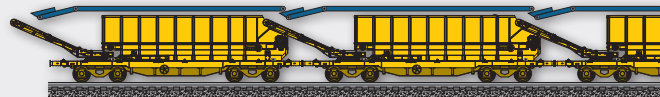

### Load and transport of new ballast from working site and waste material from ballast cleaning machine

This can be done by positioning a further conveyor belt on the upper part of each "Modulo" unit. By attaching the wagons to the Ballast Cleaning Machine in the opposite direction, it is possible to reach the working site with a new train composition consisting of a certain number of wagons – all loaded with fresh ballast, but one empty wagon.

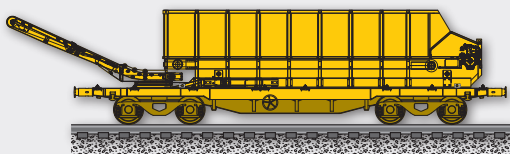

The loading platform of "Modulo" is offered with a conveyor belt system to load and transport the waste material to the following "Modulo" units.

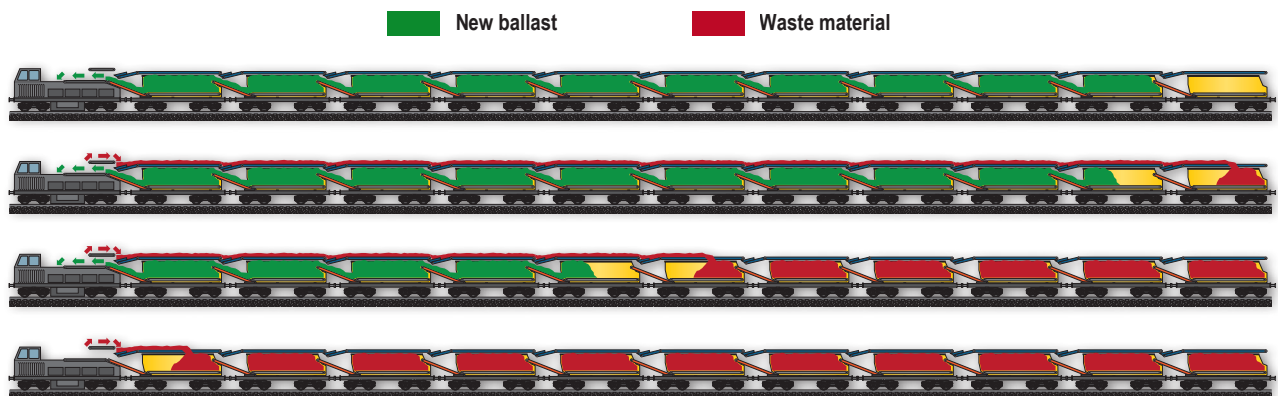

When the Ballast Cleaning Machine starts working, the waste material is transferred to the upper conveyor belts and conveyed to the last “Modulo” unit, which was purposely not loaded. At the same time, the new ballast is transferred to the Ballast Cleaning Machine by means of the lower conveyor belt of “MODULO” unit: in this way, while the new ballast is discharged, the newly available space is filled with the waste material. Given the limits of the working site lengths, using this system we are able to double the production capacity. As a matter of fact, the two traditional working trains, one for the transportation of new materials and one for loading the waste material, are no longer required. Provided that the loading system is controlled automatically, the number of workers shall be reduced; only one person is required to control both loading and unloading operations, contrary to the traditional system which required two workers, one for loading and one for unloading operations.

**Technical characteristics of “MODULO”:** Innovative system for the transportation and disposal of ballast utilising a 30 ft., or 40ft, container. It can be positioned on any type of flat wagon, provided with twist-locks, equipped with blocks for the twist locks and transportable by a container carrying truck, according to the allowed dimensions.

- Load compartment with rubber belt for a rapid and easy evacuation of the ballast,
- Walls coated with wear resisting material (Polizene);
- Back conveyor belt, foldable to facilitate the transport, with adjustable vertical and transversal inclination and side oscillation;
- Available to fit customer specifications, and for all rail gauges;
- Hydraulic unit, provided with endothermic Diesel engine of 100 kW approx., quickly interchangeable;
- Closed circuit hydraulic system for driving the conveyor belt, hopper and discharging belt;
- Open circuit hydraulic system for all other services;
- Hydraulic safety sockets, in case of failure, for the adjustment to gauge of Modulo;
- Capacity (volume): Modulo 30: 30 m<sup>3</sup> – Modulo 40: 40 m<sup>3</sup>;
- Empty weight: Modulo 30: about 10 t, Modulo 40: about 12 t;
- Length (in transport position): Modulo 30 12.500 mm – Modulo 40: 13.500 mm;
- Length (in work mode): Modulo 30: 16.000 mm – Modulo 40: 19.500 mm;
- Width (in transport/work mode): Modulo 30 and Modulo 40: 2.550 mm;
- Height (in transport position): Modulo 30= 2.550 mm – Modulo 40= 2.860 mm;
- Radio control unit to operate up to 20 Modulo units;
- Spare remote control unit, one for each Modulo, in case of failure of the radio control unit.

#### “MODULO” in combination with a Ballast Cleaning Machine:

- The wagons on which the “Modulo” units have been positioned are attached to the Ballast Cleaning Machine;
- The transport capacity of the conveyor belt, from the Ballast Cleaning Machine to the “Modulo” units, is up to 900 m<sup>3</sup>/h of waste material/ballast;
- The train for the transportation of the material is loaded in a continuous way, starting from the last unit to the first;
- Once the rear half of the “Modulo” train is loaded, those wagons are attached to a locomotive and transferred to the discharge place;
- In the meantime, the “Modulo” units which remained attached to the Ballast Cleaning Machine have been loaded;
- After having attached the wagons to the “Modulo” units loaded with ballast, the accumulated material is quickly transferred to the last half of the train just emptied;
- Working cycle can start again as soon as the first half of the “Modulo” train units is loaded again.

In this way, the Ballast Cleaning Machine can work without interruptions.

The number of “Modulo” units used depends, among other things, on the quantity of material that will be handled, on the distance between working site and discharge site and on the speed of the Ballast Cleaning Machine.

# STI20 BALLAST HANDLING SYSTEM



The system COLMAR STI 20 allows the loading, transport and unloading of the aggregates (crushed stone), with a considerable reduction of costs and time compared to conventional transport systems.

## ADVANTAGES OF COLMAR'S MATERIAL HANDLING SYSTEM:

- Reduction of ballast handling costs, of front loaders use;
- Reduction of ballast loss (about 20% of the total);
- Better preservation of the ballast, which can be piled up for, long periods;
- Less environmental pollution due to lower material dispersion;
- Reduction of the maintenance costs.
- Reduction of investment costs (Wagon Purchase);
- Reduction of the labour costs for unloading operations;
- Possibility to use the discharging belt, after having positioned said discharging belt on the top of the containers, to load debris. In case of handling harmful material (asbestos), such harmful material can be loaded directly into the containers, hermetically sealed and transported to the disposal sites.
- Increased stability: the ballast is unloaded to the center of the track (even when ballast is discharged on a curved track).

COLMAR STI 20 includes two parts: The first part consists of n. 2 standard 20 ft containers being modified in the lower part only. The capacity of such container is 20 m<sup>3</sup>. These containers can be fastened to the standard flat wagon and they are also transportable by truck, even in full load conditions. The second part consists of a conveyor belt, mounted on a steel structure to be fastened to the standard flat wagons. This structure is provided with an independent Diesel engine with hydraulic and electric unit for lighting. Everything is remote-controlled, only one transmitting unit may control up to 39 Inert Material Handling Systems.

### Technical characteristics

Empty Weight (approx.)	t	15
Max belt flow rate	m <sup>3</sup> /h	900



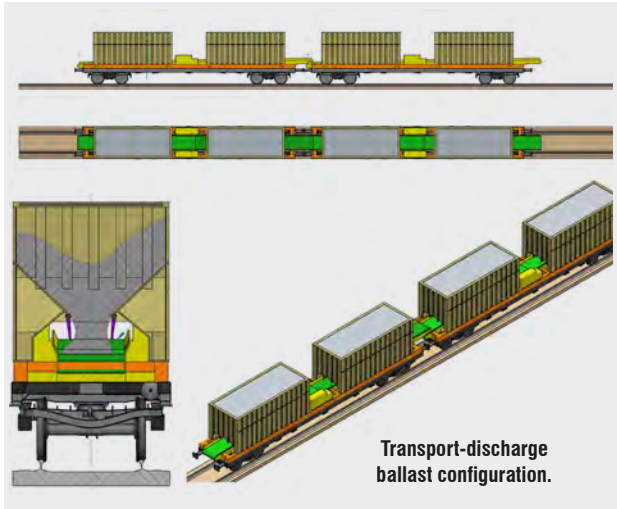

**Transport-discharge ballast configuration.**

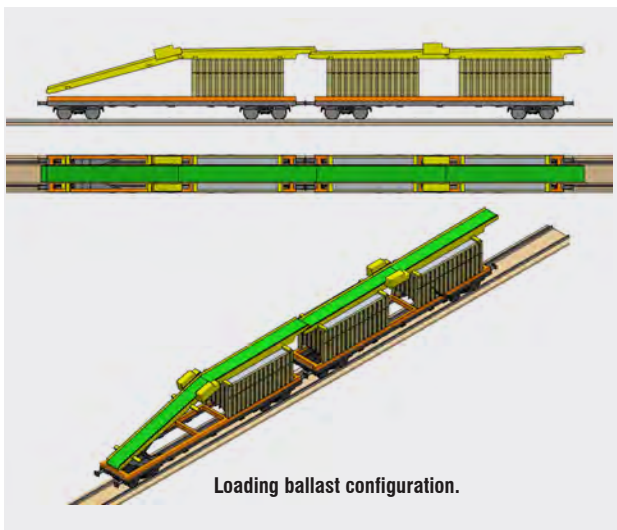

**Loading ballast configuration.**

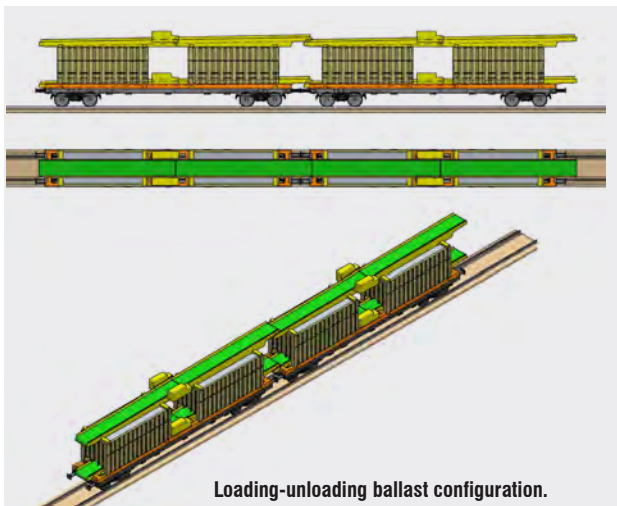

**Loading-unloading ballast configuration.**

During the transportation phase, the unloading structure is capable to withdraw itself in an automatic way allowing getting length and width sizes similar to a 40 ft. container. To facilitate this phase, this equipment can be stacked with a maximum of five pieces when empty.

The ballast can be transported by using our 20 ft. containers, which can be transported, both on rail and on road, directly from the ballast pit.

To distribute the ballast on the ballast bed, standard flat wagons for container transport can be used on which the automatic unloading system will be positioned; on the top of the automatic unloading system the two 20 ft. modules, full of ballast will be then positioned and fastened by means of twist locks, so the working train will be formed by a certain number of wagons.

At the end of these ballast-handling operations, the operator, by using the radio-control, may control the opening of the discharge outlets of the different containers as needed. The ballast will be transferred on the different conveyor belts until it reaches the end part of the train; now the ballast can be:

- Dropped on the ballast bed between the two rails;
- Distributed by using a radio-controlled ballast distributing/profiling device, both in the middle and on the track bench;
- Unloaded on the adjacent track or on the pathways both left and right, by using a radio-controlled conveyor capable to turn both to the right and to the left.

Once the distribution of the ballast is finished, the working train can go back to the depot and quickly replace the empty containers with the containers full of ballast.

**Optional:** Upper conveyor belt.





## HANDLING SYSTEM FOR TRACK SECTIONS

## SP20



Machine for the lifting and laying of track panels, switches (turnouts). Structure in sturdy electro welded steel, with 4 vertical lifting rods.  
Hydraulic pincers to grab the switches under the rail base.

The 4 vertical lifting rods allow the machine to be loaded in autonomy onto rail wagons or trucks/lorries, without the need of auxiliary systems.

Possibility of towing the machine on rail tracks by means of tow bars, after disconnecting the propeller transmission shaft. The four vertical lifting rods can, on request, be supplied with an extension of mm 1400 or mm 1800.

Longitudinal movements of the load, of 400 mm ( $\pm 200$ ).

**The movement and the alignment of the switch or of the track panel with the rail track are performed at the maximum safety level, due to the machine being equipped with 4 supporting legs.**

A service rail track allows a fast laying of the switch.

Max speed .....	10 km/h
Lifting capacity .....	20 t
Max gradient .....	45‰
Radius .....	50 m
Braking system .....	Hydraulic
Overall length .....	3275 mm
Overall width (horizontal beam fully retracted) .....	3140 mm
Max width (horizontal beams fully extended) .....	4740 mm
Heigh .....	2575 mm
Weight .....	5.5 t
Lateral movement	
- Without load .....	1500 mm ( 700 + 800 mm )
- With load .....	700 mm

Longitudinal travel of the load ..... 400 mm (+- 200 mm)

Max height of the load .....	1400 mm / 1800 mm
Rail wheel diameter .....	400 mm
Diesel engine .....	22 kW

**Optional:** Remote control

# A25/A35

## RAIL TROLLEY

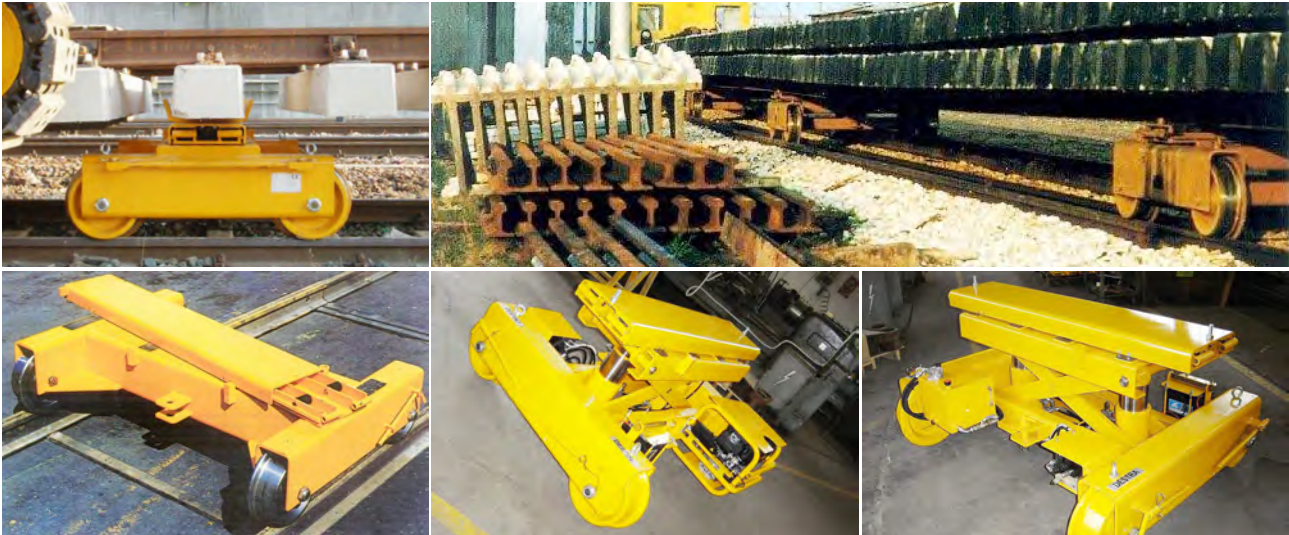

### A35 RAIL TROLLEY

Trolley with flat turning base on rollers, for lateral movements. Suitable for the transportation and positioning of switches, track panels and sleepers.

#### Technical data:

Wheel base .....	1000mm
Width .....	1900mm
Height .....	560mm
Lateral movement of the base .....	± 300mm
Base rotation .....	10°
Wheel diameter .....	350mm
Capacity .....	35t
Weight .....	950kg

SLEWING RING FOR THE SP20 ROTATION on transportation vehicle, for containment in gauge

SERVICE TRACK, segment from 1,5m

TRACK CONNECTION RAMP

### A25 RAIL MOTORTROLLEY

Trolley with flat turning base on rollers, for lateral movements. Suitable for the transportation and positioning of switches, track panels and sleepers. Diesel engine, hydraulics for the base movements.

#### Technical data:

Diesel engine .....	3,5kw
Remote command (push button panel) .....	cable
Wheel base .....	1000mm
Width .....	1900mm
Height .....	560mm
Base max. height .....	860mm
Lateral movement of the base .....	±300mm
Base rotation .....	10°
Wheel diameter .....	350mm
Capacity .....	25t
Electric system .....	12V
Weight .....	1150kg

SLEWING RING FOR THE SP20 ROTATION on transportation vehicle, for containment in gauge

SERVICE TRACK, segment from 1,5m

TRACK CONNECTION RAMP

**T7000FS**  
**T10000FS**  
**T10000HS**  
**T12000HS**

**RAIL ROAD LOADERS**



**Safety devices:**

- Rated lifting capacity indicator
- Dead man switch
- 3 emergency buttons
- Manual recovery pump
- 2 cameras for the rear and blind view with microphone
- Hydraulic and electro-hydraulic boom height limit
- Electro-hydraulic and mechanic turret swing limit
- FOPS certified cab (option one man cab)
- 12 V electric recovery pump (optional)

**COLMAR rail road loaders and excavators are the best option for all type of track maintenance.**

**COLMAR Rail road loaders are powerful, reliable, safe and very easy to use.**

They help increase productivity and reduce costs. With a huge variety of accessories, they are suitable to all work challenges that may arise in the site.

COLMAR quick connector attachments can be changed in less than two minutes and be ready for the next job.

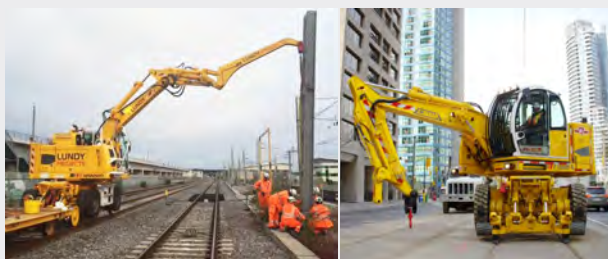

		Tyred loader <b>T7000FS</b>	Tyred loader <b>T10000FS</b>	Tyred loader <b>T10000HS</b>	Tyred loader <b>T12000HS</b>
Weight	t	22,00	31,50	31,50	37,00
Max reach	m	7.26	7.90	7.80	7.32
Max lifting capacity	t*	8.20	11.30	11.30	13.50
Lifting capacity on rail at Max reach on 360°	t*	2.10	2.65	2.65	3.20
Extendable counterweight		Optional	Yes	Yes	Yes
Diesel Engine **	KW	115 (Deutz)	115 (Deutz)	180 (Deutz)	180 (Deutz)
Displacement **	Liter	4.1	4.8	6.1	6.1
Cooling System **		Water	Water	Water	Water
Max Working Pressure	bar	350	350	330	330
Max flow of the pumps	l/min	175 + 175	175 + 175	270 + 130	270 + 130
Speed on rail	Km/h	25	19	19	19
Speed on road	Km/h	25	19	19	19
Diesel tank capacity	l	240	210	340	340
Hydraulic oil tank capacity	l	210	210	210	210

\* Lifting capacity according ISO 10567 \*\* Engines may change according to Country regulations

## RAIL ROAD EXCAVATORS

### T2400FSE

### T8000FSE



Whether it's pulling rail, or handling ballast, or cutting brush, or lifting items, or tamping sleepers or just digging and trenching - COLMAR rail road excavators will yield top productivity.

The 3 pieces boom arrangement ensures the maximum operation range with no compromise in power, smoothness, ease of operation and comfort.



		Tyred excavator <b>T2400FSE</b>	Tyred excavator <b>T8000FSE</b>
Weight	t	18,00	24,00
Max reach	m	6.58	7.00
Max lifting capacity	t*	8.00	9.50
Lifting capacity on rail at Max reach on 360°	t*	1.14	3.00
Extendable counterweight		No	No
Diesel Engine **	KW	90 (Deutz)	115 (Deutz)
Displacement **	Liter	3.6	4.1
Cooling System **		Water	Water
Max Working Pressure	bar	350	340
Max flow of the pumps	l/min	175 + 175	410
Speed on rail	Km/h	25	25
Speed on road	Km/h	25	25
Diesel tank capacity	l	240	240
Hydraulic oil tank capacity	l	210	210

\* Lifting capacity according ISO 10567 \*\* Engines may change according to Country regulations

# T10000FSC

## RAIL ROAD TRACKED LOADER



**COLMAR rail road tracked loaders are the best option for working on rugged terrains or for undertaking outstanding lifting jobs.**

**The machine features:**

- Extendable tracks
- Rubber pads
- Extendable counterweight
- Hydrostatic transmission



		Tracked loader <b>T10000FSC</b>
Weight	t	40,00
Max reach	m	7.80
Max lifting capacity	t*	11.30
Lifting capacity on rail at Max reach on 360°	t*	3.00
Extendable counterweight		Yes
Diesel Engine **	KW	115 (Deutz)
Displacement **	Liter	4.1
Cooling System **		Water
Max Working Pressure	bar	350
Max flow of the pumps	l/min	175 + 175
Speed on rail	Km/h	20
Speed on road	Km/h	3
Diesel tank capacity	l	240
Hydraulic oil tank capacity	l	210

\* Lifting capacity according ISO 10567    \*\* Engines may change according to Country regulations

## RAIL ROAD TRACKED CRANE WITH REVERSE KNUCKLE TELESCOPIC BOOM

# T10000FSCG



### The machine features:

- Extendable tracks
- Rubber pads
- Hydrostatic transmission
- More than 15 meters reach
- 5 section telescopic boom with reverse knuckle
- Heavy duty winch

COLMAR rail road tracked crane with the reverse knuckle boom is the perfect machine for working on the installation of the overhead line or undertaking lifting jobs when is required a very long reach.

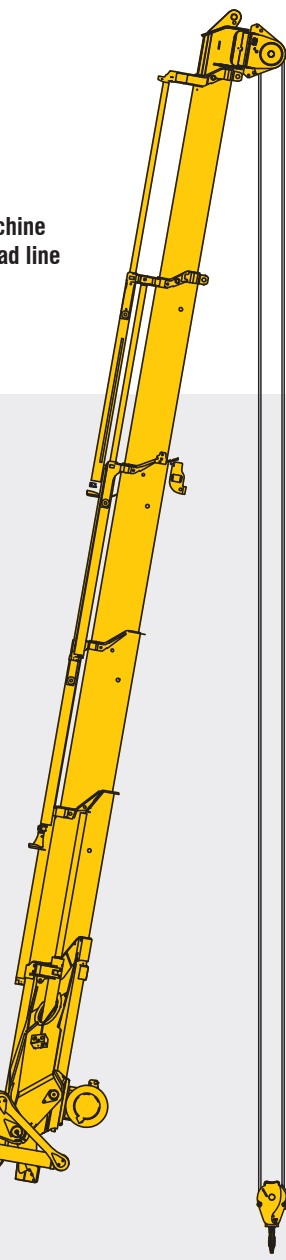

		Tracked crane <b>T10000FSCG</b>
Weight	t	39.500 kg
Max reach	m	15.2 m
Max lifting capacity with minimum working radius of 4.000 mm	t*	11.00
Front lifting capacity on track with extended boom of 14.000 mm	t*	5,0
Front lifting capacity on rail with extended boom of 14.000 mm	t*	5,0
Diesel Engine **	KW	180 (Deutz)
Displacement **	l	6,1
Cooling System **		Water
Max Working Pressure	bar	350
Max flow of the pumps	l/min	270 + 130
Speed on rail	Km/h	20
Speed on road	Km/h	3
Diesel tank capacity	l	300
Hydraulic oil tank capacity	l	250

\* Lifting capacity according ISO 10567

\*\* Engines may change according to Country regulations

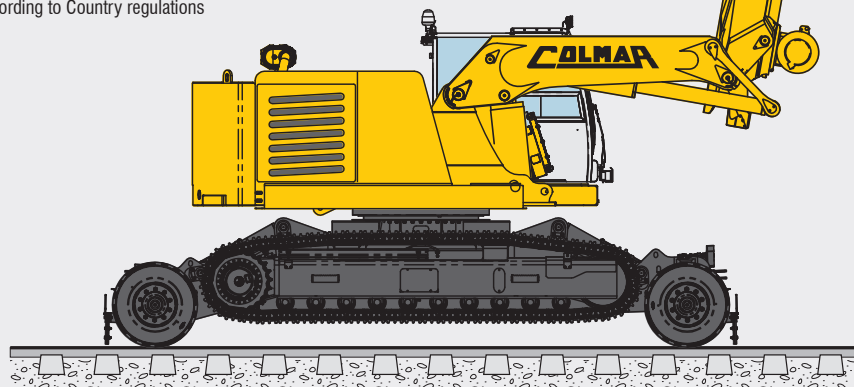



## RAIL SHEAR

# RP2000



Suitable to cut rails UNI 60

**Technical data:**

Rotation ..... 360°  
 Cutting time of rail - approx.: ..... 5 seconds  
 Weight: ..... 2.500 Kg  
 Equipped with attachment for Colmar loader 's boom

**To use the RP2000 the following Technical characteristics are required:**

Weight of the excavator between 20 to 30 t  
 Hydraulic feeding:  
 For cutting ..... 200 to 300 l/min at 350 bar of pressure  
 For the rotator ..... 25-35 l/min at 190 bar

## SLEEPERS SPREADER BEAM

# CBIPX



The Sleepers Spreader Beam allow laying the sleepers to the distance required, with mechanical adjustment of spacing, max. 750mm. The gripping maneuvers sleepers, spacing, and release are controlled hydraulically from the cab of the Loader. The beam is available in three versions for different lifting capacity of Rail Road Loaders:

- CBIP8: 8 sleepers. Weight 1.450 kg
- CBIP5: 5 sleepers. Weight 950 Kg
- CBIP4: 4 sleepers. Weight 750 Kg.



# TU03

## TAMPING UNIT



### **This equipment can be used with Railroad Loaders.**

The hammers vibration is obtained by means of an hydraulic vibration cylinder. It is possible to vary both frequency and amplitude of the vibration from the cabin of the loader.

### **To use the tamping unit tu03 the following technical characteristics are required:**

Vibrations of the tines: Hydraulic line with a flow of 100 l/min, at a max  $p=250$  bar. 360° continuous rotator, necessary to turn and place the accessory in the required position, an hydraulic line with a flow of 40 l/min, at a max  $p=150$  bar. Alternating restriction movement of the tines, a third hydraulic line with a flow of 60 l/min, at a max  $p=250$  bar. To put in operation and control the tamping unit, an electronic board should be installed inside the operator's cab.

### **ADVANTAGES:**

**The tamping system, equipped with hydraulic vibration, implies less maintenance costs in comparison with traditional (mechanical) systems.**

**The hydraulic vibration group can be effortlessly and quickly disassembled; the spare parts are very cheap and can be found easily. The maintenance staff does not need to be highly specialized.**



## BALLAST BROOM BB06



Device for cleaning the track - Excess ballast removal.  
Available for all type of gauges.

### BALLAST BROOM - BB06

Device for cleaning the track - Excess ballast removal  
Structure made of electro-welded steel plates - frame with four idle wheels.

Available for all type of gauges

Rotor with n. 6 brush rows, made of hoses: Ø 50 mm.

An hydraulic motor driven by an hydraulic pump of the loader.  
Adjustable height of the ballast broom: by hydraulic device actuated by the operator in the loader's cab.

Unloading conveyor belt, lateral right/left, also driven by the operator on the cab.

Sprinkler system for dust removal - tank capacity 400 Lt

Rotor brushes: ..... Ø 950 mm.

Power: ..... 45 kW

Working speed: ..... 800 m/h

Working width: ..... 2.600 mm

Total width: ..... 2.930 mm

Total length: ..... 2.500 mm

Weight: ..... 3.000 Kg

To use the ballast broom the following technical characteristics are required:

#### For driving the broom:

- an hydraulic feeding line with flow = 110 l/min, and p = 250 bar
- a return line
- a drainage line
- a on-off switch in the cabin for actuation

#### For driving the conveyor:

- Double acting line with flow = 30 l/min, and p = 180 bar
- a on-off switch in the cabin for actuation

For lifting the broom, a third line is required with flow 20 l/min and p = 100 bar

Weight ..... 3.000Kg

## WAGON FOR THE TRANSPORT OF RAIL ROAD LOADERS WR02

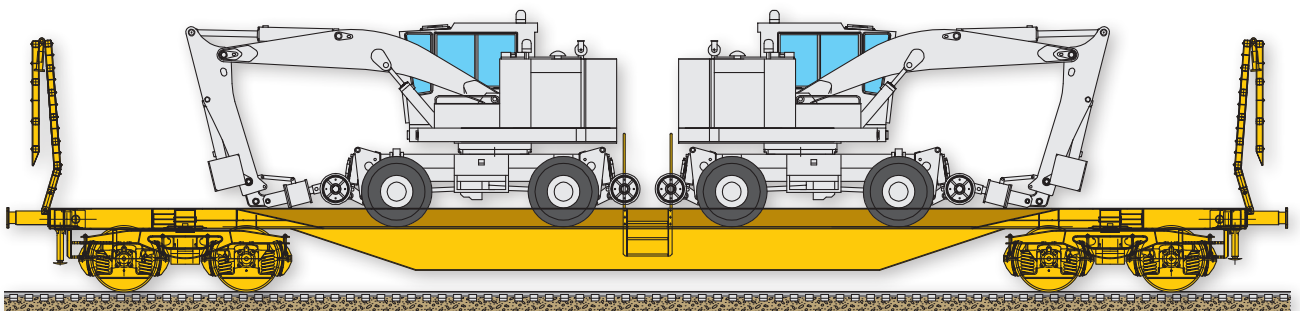

The wagon can be made available for all rail gauges and according to customer needs. Available for all type of gauges.

- Structure made of electro welded steel beams
- Hydraulically operated ramps for loading/unloading
- Axle capacity: 22,5 t
- Tare: 26 t
- Capacity: 64 t

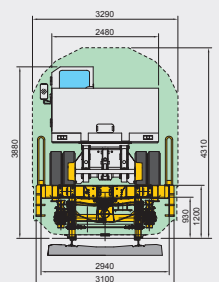
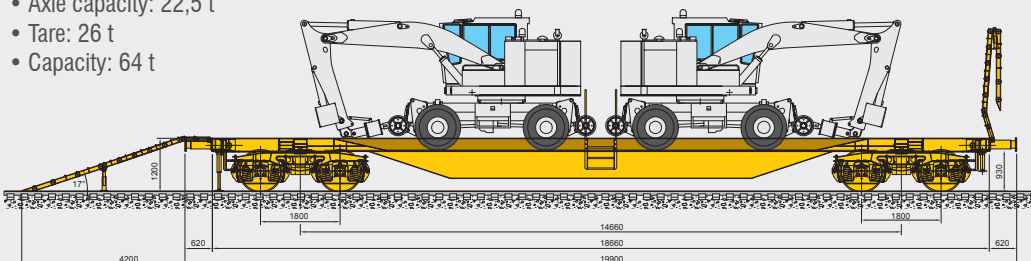

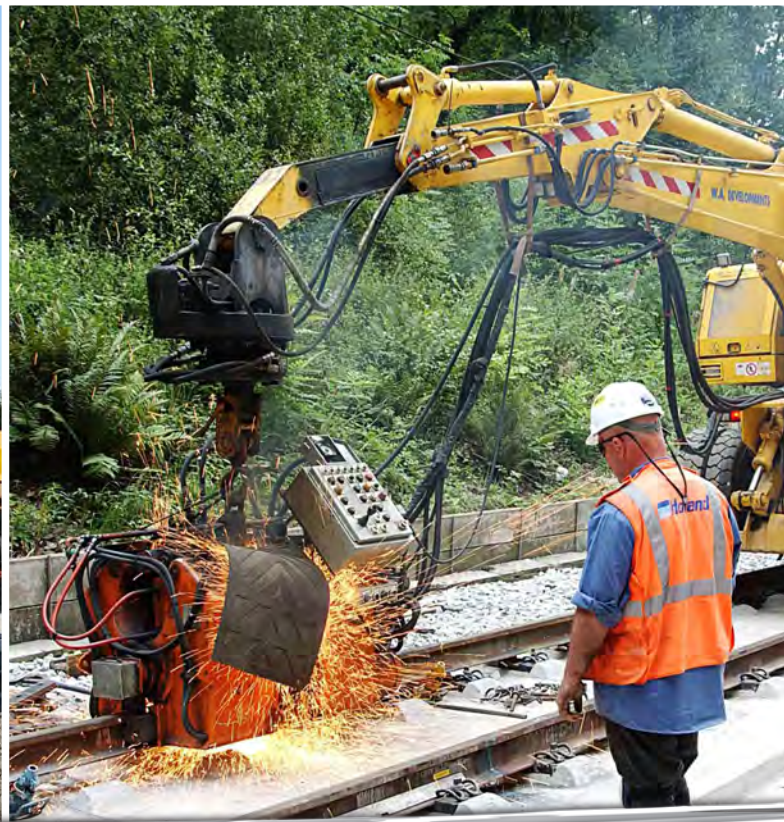

# COLMAR





# COLMAR



 **COLMAR TECHNIK S.p.A.**  
Headquarters  
Viale Regina Margherita n° 39  
45100 Rovigo ITALY  
Tel. +39 0425 932133 ( Int.4 )  
Fax +39 0425 465052  
www.colmarspa.com  
colmarspa@colmarspa.com

Export Sales Department:  
export@colmarspa.com

 **COLMAR USA, Inc.**  
U.S.A.  
3790 Commerce Ct., Suite 100  
Wheatfield, New York 14120  
1-800-537-5204  
Ph. 716 - 693 - 9877  
Fax 716 - 693 - 9869  
www.colmarequipment.com  
info@colmarequipment.com  
sales@colmarequipment.com  
service@colmarequipment.com

 **COLMAR LATINAMERICA**  
Office  
Calle 152 No. 94 A 25 Int 8.  
Bogotá D.C., Colombia, Sur América.  
Teléfono (+57) 1 535 8539  
Celular (57) 311 847 7748  
latinamerica@colmarequipment.com  
www.colmarspa.com

 **COLMAR TECHNIK (UK) LTD**  
UK  
Conrad 6 King Street  
RICHMOND Surrey England TW9 1ND  
Ph. 0161 848 8902  
www.colmar-rail.com  
colmaruk@colmarspa.com

 **COLMAR VOSTOK LTD**  
RUSSIA 115088 Moscow,  
Yuzhnoportovaya ul.7  
Ph. +7 495 5189449  
www.colmarspa.com  
info@oocolmar.ru

 **COLMAR CHINA**  
Mr. Robert Guo  
Ph.: +86 13606002609  
robert.guo@colmarspa.com

Follow us on:



**COLMAR**



FS EN 009/16 -1000

Colmar reserves the right to amend the data contained within this brochure at any time.